

PLEASE READ ALL INSTRUCTION BEFORE ATTEMPTING INSTALLATION

- 1.To prevent personal injury or product damage only licensed electricians should install.
- 2.To avoid electrical shock or component damage, disconnect power before attempting installation or servicing.
- 3.This product must be installed in accordance with the national electric code (NEC) and all applicable federal, state and local electric codes and safety standards.
- 4.Disconnect product and allow cooling prior to any further steps.
- 5.Any alteration or modification of this product is expressly forbidden as it may cause serious personal injury, death, property damage and/or product malfunction.
- 6.To prevent product malfunction and/or electrical shock this product must be properly grounded.
- 7.This luminaire is designed to operate in ambient temperatures ranging from -40°C to 50°C and to be horizontally mounted with the LED board facing downward.
- 8.The input voltage is 120V-277VAC.

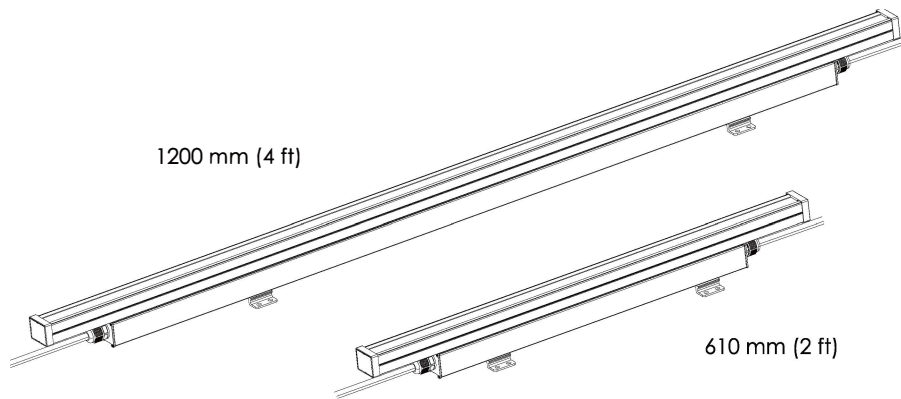

• Mount luminaires

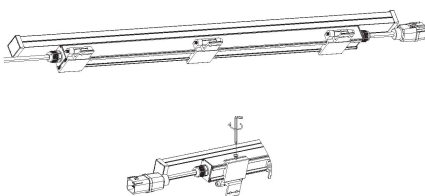

1. Slide the mounting brackets into the fixture and loosen the inner allen screws.

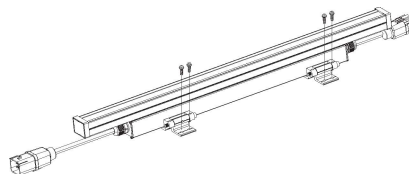

2. Secure the fixture to the wall or mounting surface by 4 screws.

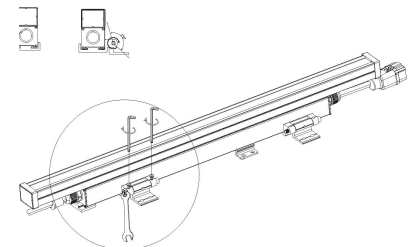

3. Aim the luminaire to the required angle and tighten the inner allen screws.

-Connect additional fixtures

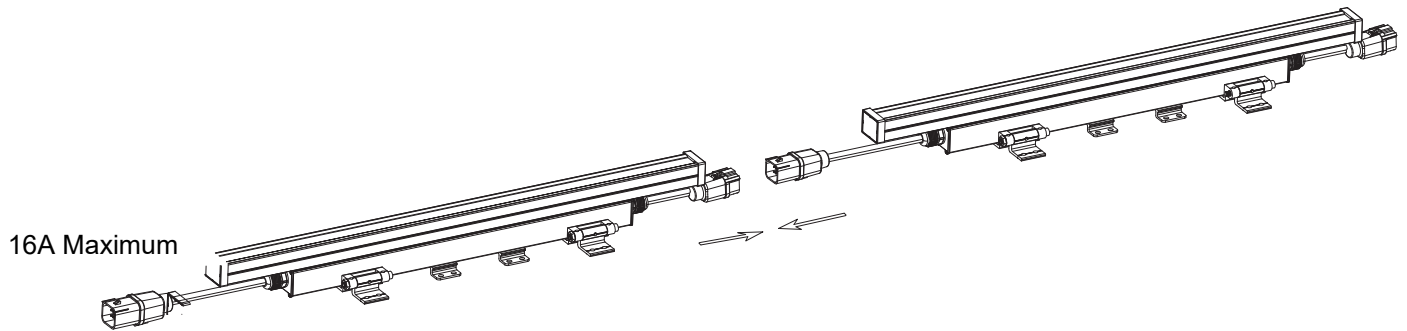

-Connect leader cable

